

FB-EI-31809-000
SHT 1.1

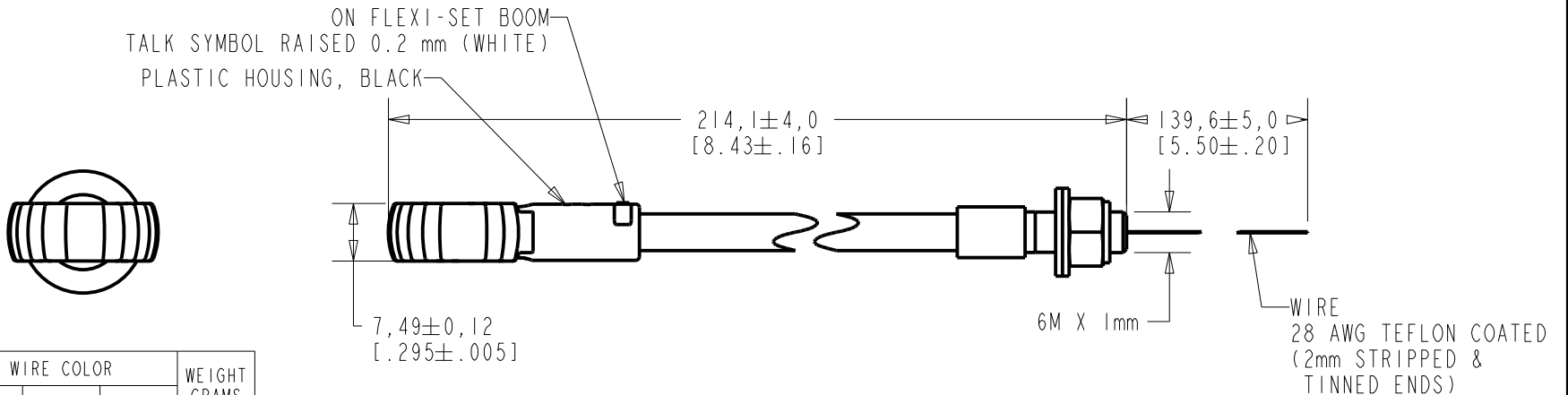
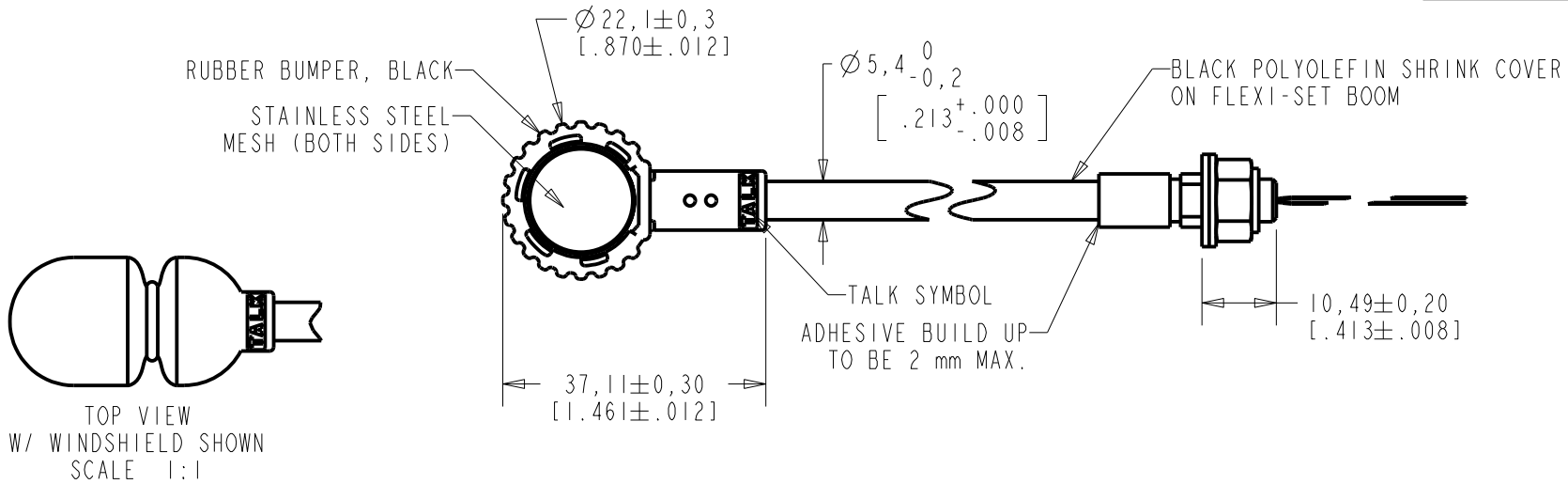

WIRE COLOR			WEIGHT GRAMS
+ve	OUTPUT	-ve	
RED	-	BLACK	t.b.d.

DIMENSIONS IN MILLIMETERS [INCHES]

Revision	C.O. #	Implementation Date	RELEASE LEVEL	REVISION
A	C40101135	10-30-12	Active	A

KNOWLES ELECTRONICS
ITASCA, ILLINOIS U.S.A.

SCALE: 1:1	DR. BY: OQ	DATE: 10-29-12
DO NOT SCALE DRAWING	CK. BY: GJP	DATE: 10-31-12
TITLE: BOOM MICROPHONE FB-EI-31809-000	APP. BY: GJP	DATE: 10-31-12
OUTLINE DRAWING	SHT 1.1	

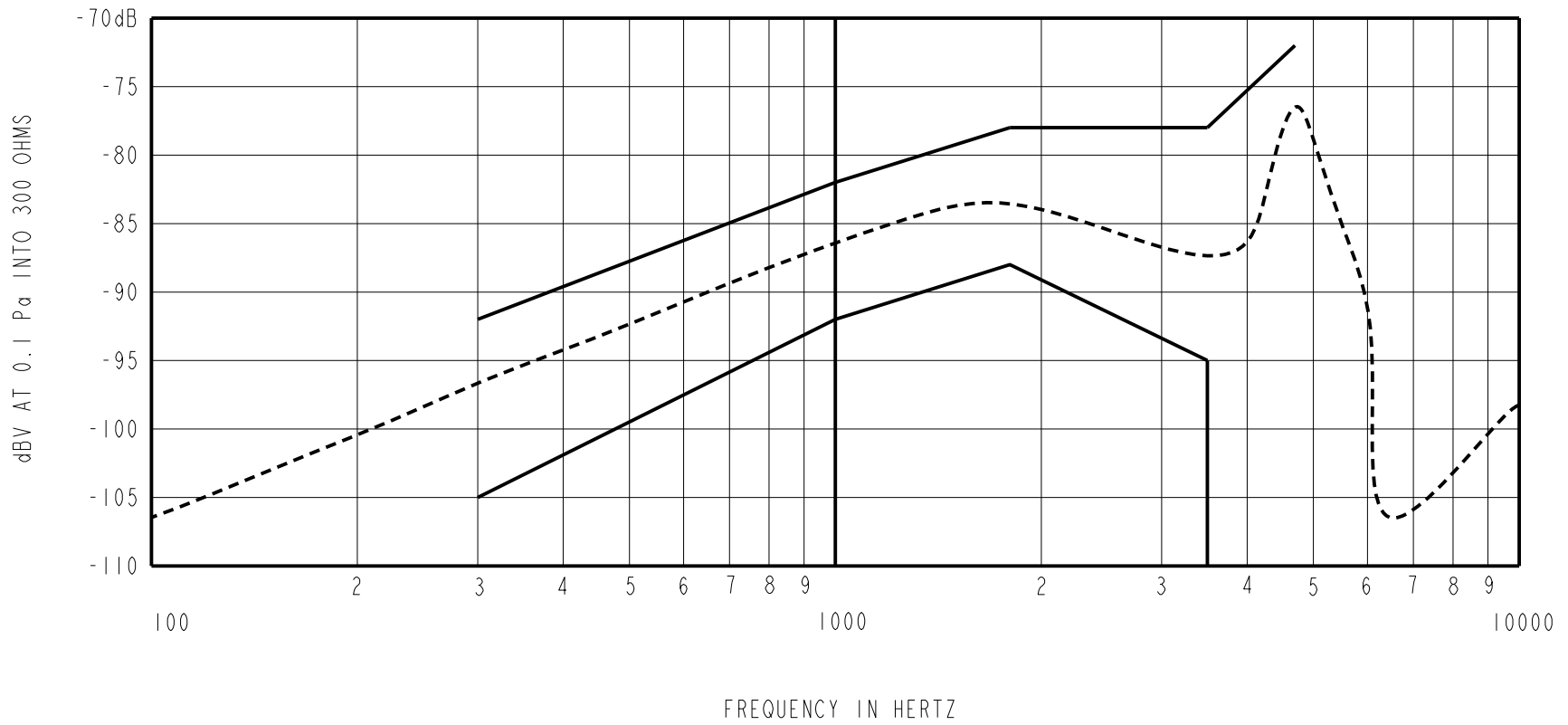

NOTES:

- SENSITIVITY VALUES INDICATED ON THIS SPECIFICATION ARE VALID AT 50% HUMIDITY.
- | FREQUENCY | SENSITIVITY | | |
|-----------|-------------|-------|------|
| | NIN. | NOM. | MAX. |
| 300 | -105 | -97.5 | -92 |
| 1000 | -92 | -87 | -82 |
| 1800 | -88 | -83 | -78 |
| 3500 | -95 | -87.5 | -78 |
| 4000 | --- | -86.5 | --- |
| 4700 | --- | -76.5 | -72 |
- TEST CONDITIONS:
HEAD OF BOOM EXPOSED TO 94 dB SPL SWEPT SOUND FIELD AT 6mm FROM VOICE APERTURE.
ARTIFICIAL VOICE:
B & k 4227 MOUTH SIMULATOR.
- FOR MICROPHONE CAPSULE SPEC. SEE DRAWING BJ-28471-000 SHEET 2.1.

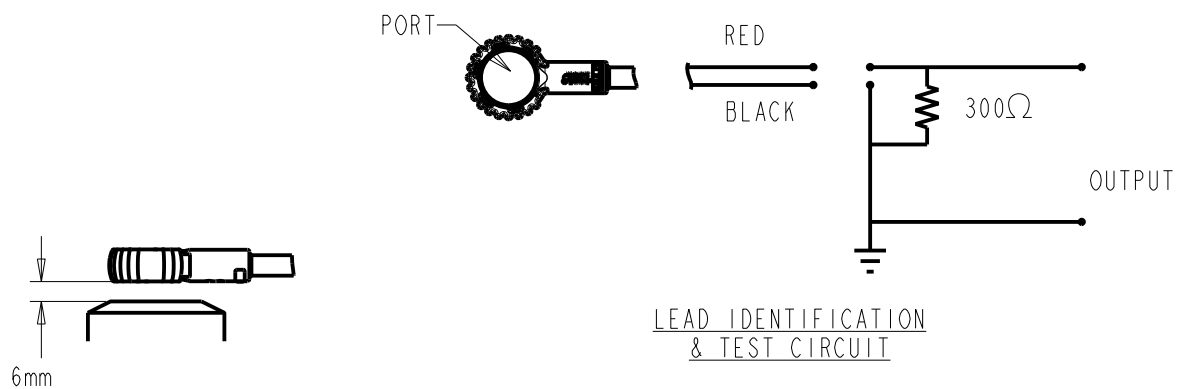

Revision	C.O. #	Implementation Date	RELEASE LEVEL	REVISION
A	C40101135	10-30-12	Active	A

WHEN TEST LIMITS ARE USED TO ESTABLISH INCOMING INSPECTION ACCEPTANCE/REJECTION CRITERIA, CORRELATION OF TEST EQUIPMENT WITH KNOWLES IS ALSO REQUIRED FOR ELIMINATION OF EQUIPMENT AND TEST METHOD VARIATION		DR. BY	DATE
		OQ	10-29-12
		CK. BY	DATE
		GJP	10-31-12
		APP. BY	DATE
		GJP	10-31-12

TITLE:	BOOM MICROPHONE	FB-EI-31809-000
	PERFORMANCE SPECIFICATION	SHT 2.1

KNOWLES ELECTRONICS
ITASCA, ILLINOIS U.S.A.